

MOLYKOTE[®]

101 Smart Lubrication Tips

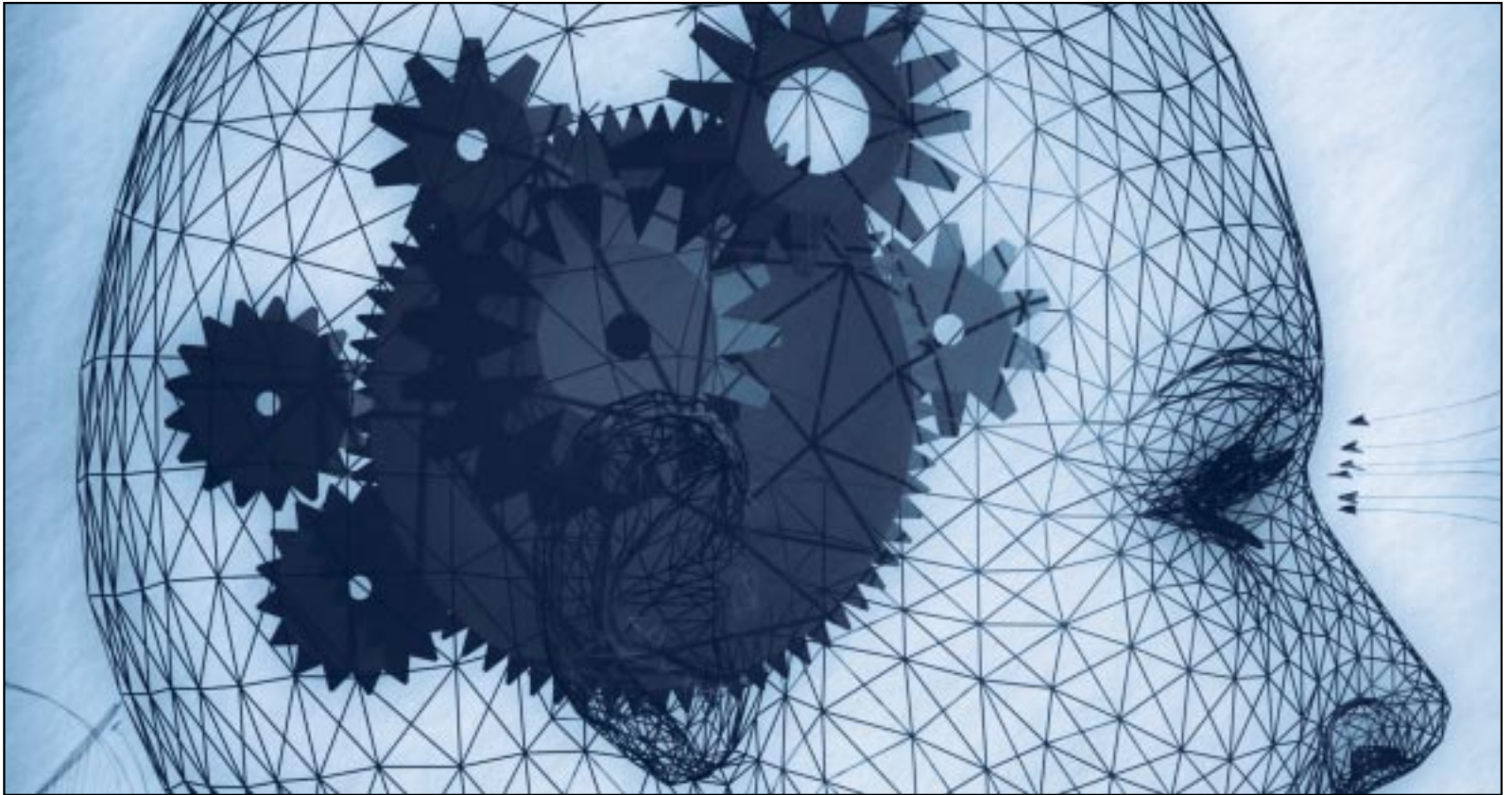

*We help you
invent the future.™*

DOW CORNING

www.dowcorning.com

Content

Solutions to your Lubrication problems

Section 1

Machine Components

- | | | | |
|---|---|----|--------------------------------------|
| 3 | <i>Rolling-element bearings</i> | 8 | <i>Linear sliding guides</i> |
| 4 | <i>Shaft/hub connections</i> | 8 | <i>Press-fit joints</i> |
| 4 | <i>Plastic gear wheels in enclosed gears</i> | 9 | <i>Chains</i> |
| 5 | <i>Steel gear wheels in open gears</i> | 10 | <i>Planetary roller screws</i> |
| 5 | <i>Seals and packings</i> | 10 | <i>Bolts, studs</i> |
| 6 | <i>Steel gear wheels in enclosed gears</i> | 11 | <i>Maintenance, repairs</i> |
| 6 | <i>Sliding contact bearings made of metal</i> | 12 | <i>Vacuum pumps, Air compressors</i> |
| 7 | <i>Sliding contact bearings made of plastic</i> | 12 | <i>Hydraulic pumps</i> |
| 7 | <i>Linear motion guides</i> | | |

We trust you'll find solutions to your many lubrication needs in this document. If we don't have a specific MOLYKOTE® solution listed for your application, please CONTACT US at (www.molykote.com) so we can find the right solution for you.

Solutions to your Lubrication problems

Machine Components

MOLYKOTE® Solution



Rolling-element bearings

User problem	Requirement	MOLYKOTE® Solution			
		Europe	Americas	Japan	Asia
Short life due to high loads	Multi-purpose grease with MoS2	BR2 Plus	BR2 Plus	BR2 Plus	BR2 Plus
	Extreme pressure and water resistant grease	Longterm 2 Plus	Longterm 2 Plus	Contact Us	Longterm 2 Plus
Ability to operate at extremely low temperatures (to -70°C)	Low to moderate loads and speeds	33	33	33	33
Short life due to high temperatures (up to 160°C continuous)	Moderate to high loads and low to moderate speeds	FB 180	G-4700	Contact Us	FB 180
Short life due to very high temperatures (up to 180°C continuous)	Moderate to high loads and high speeds	BG 20	BG 20	Contact Us	BG 20
Short life due to very high temperatures (up to 200°C continuous)	Low to moderate loads and speeds	44	44	44	44
Short life due to extremely high temperatures (up to 250°C continuous)	Resistant against solvents and other aggressive chemicals	BG 87	HP-870	HP-870/HP-500	HP-870
Short life due to extremely high temperatures (up to 230°C continuous)	Heavy duty and chemically resistant grease	FS 3451	FS 3451	FS 3451	FS 3451
Short life due to extremely high temperatures (up to 230°C continuous)	Low to moderate loads and speeds	7348	41	Contact Us	7348
Need for operation in very high vacuum environment	Service temperatures from -35 to +250°C	HP-300	HP-300	HP-300	HP-300
Lubricant failure because of aggressive environmental influence	Service temperatures from -35 to +250°C	BG 87	HP-870	HP-870/HP-500	HP-870
	Service temperatures from -35 to +250°C	HP-300	HP-300	HP-300	HP-300
	Service temperatures from -40 to +200°C	FS 1292	FS 1292	Contact Us	FS 1292
	Service temperatures from -40 to +230°C	FS 3451	FS 3451	FS 3451	FS 3451
Noise	Service temperatures from -40 to +150°C	BG 555	Contact Us	Contact Us	Contact Us

We trust you'll find solutions to your many lubrication needs in this document. If we don't have a specific MOLYKOTE® solution listed for your application, please CONTACT US at (www.molykote.com) so we can find the right solution for you.

Solutions to your Lubrication problems

Machine Components

		MOLYKOTE® Solution				
	User problem	Requirement	Europe	Americas	Japan	Asia
	Stick-slip and damage during assembly and running-in	Dry film lubricant coating Pretreatment with solid lubricants Adhesive pretreatment assembly paste	D 321 R G-Rapid Plus G-n Plus	D 321 77 Paste G-n Paste	D 321 R G-Rapid Paste G-n paste	D 321 R G-Rapid Plus G-n Plus
	High wear, stiff operation, fretting corrosion, increased tolerances	Multi-purpose grease with MoS2 Extreme pressure MoS2 grease Fretting corrosion	BR 2 Plus Longterm 2 Plus P 40	BR 2 Plus Longterm 2 Plus P 40	BR 2 Plus Contact Us Contact Us	BR 2 Plus Longterm 2 Plus P 40
	Short life and lubrication intervals owing to wet environment	White long-life and water resistant grease Extreme pressure and water resistant grease	Longterm W2 Longterm 2 Plus	G-807 Longterm 2 Plus	Longterm W2 Contact us	Longterm W2 Longterm 2 Plus

Shaft/hub connections

Machine Components

		MOLYKOTE® Solution				
	User problem	Requirement	Europe	Americas	Japan	Asia
	Running-in damage, stick-slip, scuffing, seizure	White synthetic grease with solid lubricants General purpose grease for plastic lubrication	PG-30L PG-602	PG-30L G - 4500	EM-30L Grease X5-6020	EM-30L/EM-30LG X5-6020
	High wear and short life owing to high temperatures or heavy loads. Swelling, shrinking, stress cracks, change in strength characteristics due to inadequate lubricant	White silicone grease for wide temperature range	PG 21	Contact Us	Contact Us	PG 21
		White synthetic grease with solid lubricants for extreme pressure	PG-30L	PG-30L	EM-30L Grease	EM-30L/EM-30LG
		White silicone grease with solid lubricants	PG 54	PG 54	Contact Us	PG 54
		Semi-synthetic grease for enclosed plastic and steel gears	G 68	Contact Us	Contact Us	G 68
		General purpose, semi-synthetic grease	PG 75	Contact Us	Contact Us	PG 75
		General purpose grease for plastic lubrication	PG-602	Contact Us	EM-30L Grease	X5-6020
		Synthetic grease with solid lubricants for extreme pressure	YM-103	YM-103	YM-103/YM-102	YM-103

Plastic gear wheels in enclosed gears

We trust you'll find solutions to your many lubrication needs in this document. If we don't have a specific MOLYKOTE® solution listed for your application, please CONTACT US at (www.molykote.com) so we can find the right solution for you.

Solutions to your Lubrication problems

Machine Components

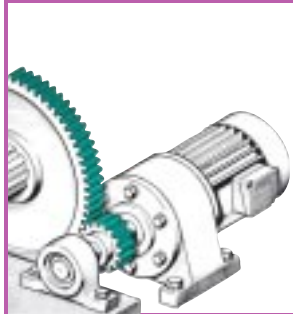

Steel gear wheels in open gears

User problem	Requirement	MOLYKOTE® Solution			
		Europe	Americas	Japan	Asia
High wear, pitting or corrosion on gear wheels running at low to medium speeds (up to 2 m/s)	Adhesive pretreatment assembly paste	G-n Plus	G-n Paste	G-n	G-n Plus
	Pretreatment with solid lubricants	G-Rapid Plus	77 Paste	G-n Rapid Paste	G-Rapid Plus
	Protection against fretting corrosion	TP 42	Contact Us	Contact Us	TP 42
	Adhesive grease against fretting corrosion	G 67	Contact Us	Contact Us	G 67
	Protects against wear due to high loads	165 LT	Contact Us	Contact Us	165 LT
	Synthetic grease with solid lubricants	1122	1122	Contact Us	1122
High wear, pitting or corrosion on gear wheels running at high speeds (up to 6 m/s)	Good water and moisture resistant grease (spray)	S-1004	Contact Us	Contact Us	Contact Us
	Adhesive grease in difficult operating conditions	1122	1122	Contact Us	1122

Machine Components



Seals and packings

User problem	Requirement	MOLYKOTE® Solution			
		Europe	Americas	Japan	Asia
Damage due to lubrication failure under aggressive environmental influences	Resistant against solvents and other aggressive chemicals	BG 87	HP 870	HP 870	HP-870
	Silicone compound resistant against solvents and gases	111	111	111	111
	Chemically resistant fluoro-silicone grease	FS 3452	FS 3452	FS 3452	FS 3452
Shrinkage, swelling and stress cracking due to lubricant incompatibility	White synthetic grease with solid lubricants compatible with many plastics	PG-30L	G - 4500	EM-30L Grease	EM-30L/EM-30LG
	Synthetic grease with noise dampening capacity	EM-50L	EM-50L	EM-50L	EM-50L
	Low temperature synthetic grease compatible with many plastics	EM-60L	EM-60L	EM-60L	EM-60L
	Synthetic grease compatible with many plastics, protects against stress-cracking formation	BG 87	HP 870	HP 870	HP-870
	General purpose silicone compound	111	111	111	111

We trust you'll find solutions to your many lubrication needs in this document. If we don't have a specific MOLYKOTE® solution listed for your application, please CONTACT US at (www.molykote.com) so we can find the right solution for you.

Solutions to your Lubrication problems

Solutions to your Lubrication problems

Machine Components

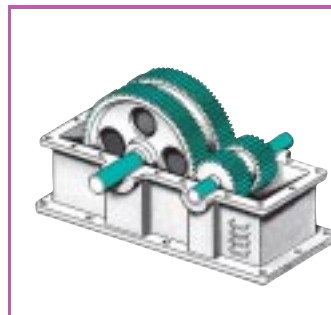

Steel gear wheels in enclosed gears

User problem	Requirement	MOLYKOTE® Solution			
		Europe	Americas	Japan	Asia
Running-in damage	Pretreatment assembly paste	G-Rapid Plus	G - n Paste	G-Rapid Paste	G-Rapid Plus
	Dry film lubricant coating	D 321 R	321	D 321 R	D 321 R
Wear, pittings	MoS2 additive for gear oils	M 55 Plus	M Gear	M Dispersion	M 55 Plus
	Adhesive, semi-fluid mineral oil grease	Longterm 00	Contact Us	Contact Us	Longterm 00
	Synthetic grease with solid lubricants	1122	1122	Contact Us	1122
Short life due to high temperatures, high load in helical steel drive gears	Good oxidation and thermal stability	L-1115 - ISO 150	L-1115 - ISO 150	L-1115 - ISO 150	L-1115 - ISO 150
Short life due to high temperatures (≥75°C) in helical steel drive gears in food processing plant	Good oxidation and thermal stability	L-1115FG - ISO 150	L-1115FG - ISO 150	L-1115FG - ISO 150	L-1115FG - ISO 150
	Food grade				
High maintenance cost due to frequent oil changes in worm gears that are difficult to access	Synthetic food grade gear oil	L-1146 FG - ISO 460	L-1146 FG - ISO 460	L-1146 FG - ISO 460	L-1146 FG - ISO 460
Corrosion protection in worm gears made out of bronze	No sulphur phosphorous EP additives	L-1146 - ISO 460	L-1146 - ISO 460	L-1146 - ISO 460	L-1146 - ISO 460
Steel gears in area of a food processing plant, prone to frequent washdowns	Food grade High resistance to water emulsification	L-1115FG - ISO 150	L-1115FG - ISO 150	L-1115FG - ISO 150	L-1115FG - ISO 150

Machine Components

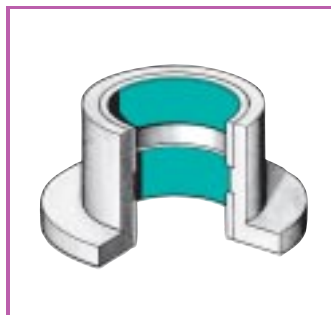

Sliding contact bearings made of metal

User problem	Requirement	MOLYKOTE® Solution			
		Europe	Americas	Japan	Asia
Stick-slip and damage during assembly and running-in	Dry film lubricant coating	D 321 R	321	D 321 R	D 321 R
	Adhesive pretreatment assembly paste	G-n Plus	G-n Paste	G-n	G-n Plus
	Pretreatment assembly paste	G-Rapid Plus	77 Paste	G-Rapid Paste	G-Rapid Plus
Scuffing, scoring, high wear. Short life due to high load	Multi-purpose grease with MoS2	BR 2 Plus	BR 2 Plus	BR 2 Plus	BR 2 Plus
	Extreme pressure MoS2 grease	Longterm 2 Plus	Longterm 2 Plus	Contact Us	Longterm 2 Plus
Short life and lubrication intervals owing to wet environment	White long-life and water resistant grease	Longterm W2	Contact Us	Longterm W2	Longterm W2
	Extreme pressure and water resistant grease	Longterm 2 Plus	Longterm 2 Plus	Contact Us	Longterm 2 Plus

We trust you'll find solutions to your many lubrication needs in this document. If we don't have a specific MOLYKOTE® solution listed for your application, please CONTACT US at (www.molykote.com) so we can find the right solution for you.

Solutions to your Lubrication problems

Machine Components	MOLYKOTE® Solution					
	User problem	Requirement	Europe	Americas	Japan	Asia
 <p>Sliding contact bearings made of plastic</p>	Running-in damage, stick-slip, scuffing, seizure	White synthetic grease with solid lubricants	PG-30L	PG-30L	EM-30L Grease	EM-30L/EM-30LG
		Extreme pressure synthetic grease paste	PPE	Contact Us	E Paste	E
	High wear, stiff operation, stress cracks, swelling, shrinking, effect on hardness due to inadequate lubricant, short life owing to high temperatures or high loads	General purpose grease for plastic lubrication	PG 602	PG 602	X5-6020	X5-6020
		White silicone grease for wide temperature range	PG 21	Contact Us	Contact Us	PG 21
		White synthetic grease with solid lubricants for extreme pressure	PG-30L	PG-30L	EM-30L Grease	EM-30L/EM-30LG
		White silicone grease with solid lubricants	PG 54	PG 54	Contact Us	PG 54
		General purpose, semi-synthetic grease	PG 75	PG 75	Contact Us	PG 75
		General purpose grease for plastic lubrication	PG 602	G - 4500	X5-6020	X5-6020
Synthetic grease with solid lubricants for extreme pressure	YM-103	YM-103	YM-103/YM-102	YM-103		

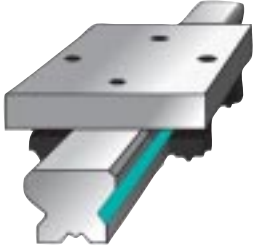
Machine Components	MOLYKOTE® Solution					
	User problem	Requirement	Europe	Americas	Japan	Asia
 <p>Linear motion guides</p>	High lubricant usage with oil lubrication	Coat with AF Coating then apply thin film of DX paste	3402 C + DX	3402 C + DX	3402 C + DX	3402 C + DX
	High wear due to intermittent operation or by small movement	Dry film lubricant for short travel distances	3402 C	3402 C	3402 C	3402 C
	Insufficient accuracy as a result of surface rolling and wear	Apply both lubricants due to increased loads	3402 C + DX	3402 C + DX	3402 C + DX	3402 C + DX
		Apply both lubricants due to high loads and medium speeds	3402 C + Longterm 2 Plus	3402 C + Longterm 2 Plus	Contact Us	3402 C + Longterm 2 Plus

We trust you'll find solutions to your many lubrication needs in this document. If we don't have a specific MOLYKOTE® solution listed for your application, please CONTACT US at (www.molykote.com) so we can find the right solution for you.

Solutions to your Lubrication problems

Machine Components

MOLYKOTE® Solution

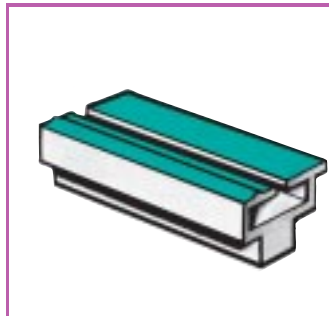

Linear sliding guides

User problem	Requirement	Europe	Americas	Japan	Asia
Stick-slip and damage during assembly and running-in	Adhesive pretreatment assembly paste	G-n Plus	G-n Paste	G-n	G-n Plus
	Pretreatment assembly paste	G-Rapid Plus	77 Paste	G-Rapid Paste	G-Rapid Plus
	Multi-purpose grease with MoS2	BR 2 Plus	BR 2 Plus	BR 2 Plus	BR 2 Plus
	Extreme pressure MoS2 grease	Longterm 2 Plus	Longterm 2 Plus	Contact Us	Longterm 2 Plus
Scuffing, scoring, high wear, short life due to high load	Multi-purpose, moderate load and food grade (USDA H1) grease	G-4500	G-4500	G-4500	G-4500
	Synthetic grease for high loads on metals	G-4700	G-4700	YM-102	G-4700
	General purpose, semi-synthetic grease	PG 75	PG 75	Contact Us	PG 75
	White synthetic grease with solid lubricants for extreme pressure	PG-30L	Contact Us	EM-30L Grease	EM-30L/EM-30LG
	Silicone grease for plastics with wide temperature range	33	33	33	33
	Short life and lubrication intervals owing to wet environment	White long-life and water resistant grease	Longterm W2	Contact Us	Longterm W2
Fretting corrosion	Extreme pressure and water resistant grease	Longterm 2 Plus	Longterm 2 Plus	Contact Us	Longterm 2 Plus
	White, extreme pressure solid lubricant paste	DX	DX	DX	DX
Fretting corrosion	Adhesive lubricant against fretting corrosion	G 67	G 67	Contact Us	G 67

Machine Components

MOLYKOTE® Solution

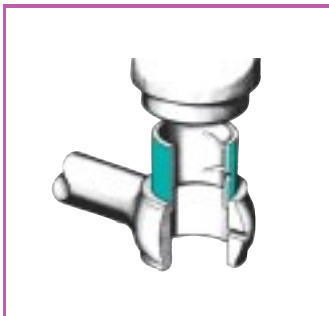

Press-fit joints

User problem	Requirement	Europe	Americas	Japan	Asia
Difficult and time consuming assembly because of stick-slip; scuffing, scoring or component damage during press-fitting	Adhesive pretreatment assembly paste	G-n Plus	G-n Paste	G-n	G-n Plus
	White assembly paste	D	D	DX	D
	Pretreatment with solid lubricants	G-Rapid Plus	77 Paste	G-Rapid	G-Rapid Plus

We trust you'll find solutions to your many lubrication needs in this document. If we don't have a specific MOLYKOTE® solution listed for your application, please CONTACT US at (www.molykote.com) so we can find the right solution for you.

Solutions to your Lubrication problems

Machine Components

MOLYKOTE® Solution

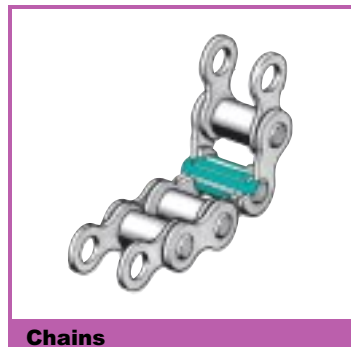

Chains

User problem	Requirement	MOLYKOTE® Solution			
		Europe	Americas	Japan	Asia
High wear and short service life caused by high temperatures or heavy loads	Semi-synthetic chain oil	S-1500	C - 40	Contact Us	S-1500
	High temperature synthetic chain oil	S-1501	C - 40	Contact Us	S-1501
	Service temperatures from -30 to +250°C	S-1502	C - 40	Contact Us	S-1502
	High temperature / low friction synthetic chain oil, up to +250°C	S-1503	C - 40	Contact Us	S-1503
	Adhesive / low friction synthetic chain oil, up to +250°C	S-1504	C - 40	Contact Us	S-1504
	Solvent free high temperature chain oil	CO 220	C - 40	Contact Us	CO 220
High wear and short service life due to insufficient lubrication at high speeds	Adhesive chain lubricant with MoS2	MKL-N	Contact Us	Contact Us	MKL-N
High wear and short service life caused by extreme temperatures or heavy loads	Dry lubrication by solid lubricants up to +450°C	M 30	Contact Us	M 30	M 30
High wear and corrosion due to heavy loads and wet environments	Black chain lubricant for grease nipples	1122	1122	Contact Us	1122
	Adhesive paste for normal and stainless steel chains	P 40	P 40	Contact Us	P 40
High wear and corrosion due to high water washout	High resistance to water emulsification	L-1460FG	L-1460FG	L-1460FG	L-1460FG
	High film strength				
High wear and short service life caused by very low temperatures	Food grade	L-1468FG	L-1468FG	L-1468FG	L-1468FG
	Pour point < -60°C				

We trust you'll find solutions to your many lubrication needs in this document. If we don't have a specific MOLYKOTE® solution listed for your application, please CONTACT US at (www.molykote.com) so we can find the right solution for you.

Solutions to your Lubrication problems

Machine Components

		MOLYKOTE® Solution				
User problem		Requirement	Europe	Americas	Japan	Asia
	Contamination as a result of high lubricant delivery during oil lubrication	Dry film, oil resistant lubricant	7409	7409	7409	7409
	Increased wear caused by lubricant oxidation or decomposition at extreme temperatures or under aggressive ambient conditions	Silicone grease for high and very low temperatures	33	33	33	33
		Silicone grease with wide temperature range	44	44	44	44
		Chemically resistant fluoro-silicone grease	FS 3451	FS 3451	FS 3451	FS 3451
Wear caused by high centrifugal forces at the bearing guide system as a result of high speeds	General purpose grease	Multilub	G - 4700	Contact Us	Multilub	
	Synthetic grease for high speeds	BG 20	BG 20	Contact Us	BG 20	

Planetary roller screws

Machine Components

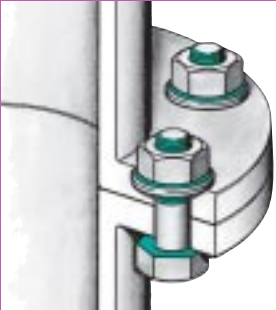
		MOLYKOTE® Solution				
User problem		Requirement	Europe	Americas	Japan	Asia
	Fretting and seizure on bolts made of austenitic stainless steel	White assembly paste	D	D	Contact Us	D
		Black, metal-free assembly paste	P 74	P 74	1000	P 74
		Dry film lubricant coating	D 321 R	321	D 321 R	D 321 R
Fretting and seizure on bolts with galvanized surface	Very low assembly torque	G-Rapid Plus	G-Rapid Plus	P 37	G-Rapid Paste	G-Rapid Plus
		Dry coating preferred	D 321 R	321	D 321 R	D 321 R
Broken bolts and stripped threads owing to scatter of friction coefficient	Consistent assembly torque	1000	1000	1000	1000	1000
		Dry film lubricant coating	7405	7405	Contact Us	7405
Fretting and seizure on bolts exposed to low to medium temperatures and corrosive environments	Metal-free lubricating paste	P 40	P 40	Contact Us	P 40	
Broken bolts due to stress cracks on thread surfaces	High temperature threads (nickel alloys)	P 37	P 37	P 37	P 37	
Seizure or broken bolts due to unsuitable lubricants	Multi-purpose copper paste	P 1600	1000	Contact Us	Contact Us	
Seizure or broken bolts due to high temperature and corrosive environments	High temperature antiseize paste	HSC Plus	Contact Us	P 37	HSC Plus	

Bolts, studs

We trust you'll find solutions to your many lubrication needs in this document. If we don't have a specific MOLYKOTE® solution listed for your application, please CONTACT US at (www.molykote.com) so we can find the right solution for you.

Solutions to your Lubrication problems

Machine Components

MOLYKOTE® Solution



Maintenance, repairs

User problem	Requirement	MOLYKOTE® Solution			
		Europe	Americas	Japan	Asia
Difficult dismantling owing to corrosion and rust	'5 in 1'	Multigliss	Moly - Penelube	Contact Us	Multigliss
	Penetrating oil	Supergliss	Penelube	Supergliss	Supergliss
Contaminated components	Metal / Brake cleaner	Metal Cleaner	OS-2	Contact Us	Contact Us
Stick-slip and damage during assembly and running-in	Adhesive pretreatment assembly paste	G-n Plus	G-n Paste	G-n	G-n Plus
	Pretreatment with solid lubricants	G-Rapid Plus	77 Paste	G-Rapid Paste	G-Rapid Plus
Corroded components due to corrosive environment	Adhesive copper paste	Cu-7439 plus	Cu-7439 plus	Cu- 7439	Cu-7439 plus
Seized or broken bolted connections	White assembly paste	D	D	Contact Us	D
	Pretreatment with solid lubricants	G-Rapid Plus	77 Paste	G-Rapid Paste	G-Rapid Plus
	Consistent assembly torque	1000	1000	1000	1000
	High temperature threads (nickel alloys)	P 37	P 37	P 37	P 37
Wear, pittings and noise	MoS2 additive for motor and gear oils	A	M Gear	Contact Us	Contact Us
Corrosion	Dry, transparent corrosion protector	Metal Protector Plus	Metal Protective Coating	Contact Us	Metal Protector Plus
Difficult applications which are not equipped with grease nipples	Low viscosity solid lubricant dispersion	Omnigliss	Contact Us	Contact Us	Omnigliss
Short life and lubrication intervals owing to wet environment.	Adhesive lubricant dispersion	Polygliss-N	Contact Us	Contact Us	Contact Us
Welding spots on welding tools and metal surfaces	Transparent, water based fluid	S-1000	Contact Us	Contact Us	Contact Us
Sticking of molded components	Non silicone release fluid	S-1001	Contact Us	Contact Us	Contact Us
Dust contamination in electrical components	Electrical contact cleaner	S-1002	Contact Us	Contact Us	Contact Us
Damage of drills and components	Cutting fluid	S-1003	Contact Us	Contact Us	Contact Us
Sticking of rubber, metal and plastic parts	Silicone release agent and lubricant	Separator Spray	Contact Us	Contact Us	Contact Us
Repair damaged galvanized surfaces	Corrosion protective dry film coating	L-0500	Contact Us	Contact Us	L-0500

We trust you'll find solutions to your many lubrication needs in this document. If we don't have a specific MOLYKOTE® solution listed for your application, please CONTACT US at (www.molykote.com) so we can find the right solution for you.

Solutions to your Lubrication problems

Machine Components

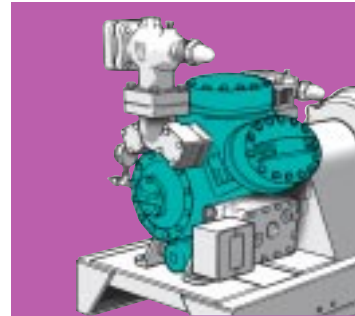

**Vacuum pumps,
Air compressors**

User problem	Requirement	MOLYKOTE® Solution			
		Europe	Americas	Japan	Asia
Short lubricant lifetime, faulty pump performance	Good oxidation and thermal stability	L-0610	L-0610	L-0610	L-0610
Short service life due to high exposure to water vapour in food processing environment	Food grade High resistance to water emulsification	L-1668FG	L-1668FG	L-1668FG	L-1668FG
Short service life due to varnish built up	Good oxidation and thermal stability	L-0246	L-0246	L-0246	L-0246
Short service life due to high temperatures	Synthetic base oil (PAO)	L-1246	L-1246	L-1246	L-1246
	Food grade	L-1246FG	L-1246FG	L-1246FG	L-1246FG
	Synthetic base oil (PAG/POE blend)	L-3232	L-3232	L-3232	L-3232
Short service life due to very high temperatures and pressures (as in piston compressors)	Synthetic base oil (POE)	L-4646	L-4646	L-4646	L-4646

Machine Components

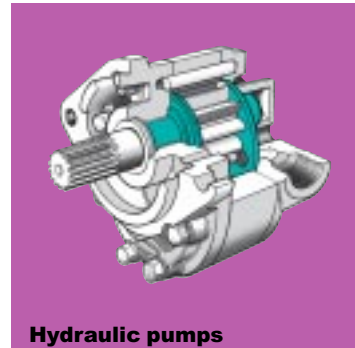

Hydraulic pumps

User problem	Requirement	MOLYKOTE® Solution			
		Europe	Americas	Japan	Asia
Extend service life	Good oxidation and thermal stability	L-0346	L-0346	L-0346	L-0346
Short service life due to water emulsification	High resistance to water emulsification	L-1346	L-1346	L-1346	L-1346
	Food grade	L-1346FG	L-1346FG	L-1346FG	L-1346FG
Low pourpoint oil	Wide temperature range (-60 to +250°C)	L-1368FG	L-1368FG	L-1368FG	L-1368FG

We trust you'll find solutions to your many lubrication needs in this document. If we don't have a specific MOLYKOTE® solution listed for your application, please CONTACT US at (www.molykote.com) so we can find the right solution for you.

LIMITED WARRANTY INFORMATION - PLEASE READ CAREFULLY

The information contained herein is offered in good faith and is believed to be accurate. However, because conditions and methods of use of our products are beyond our control, this information should not be used in substitution for customer's tests to ensure that Dow Corning's products are safe, effective, and fully satisfactory for the intended end use. Suggestions of use should not be taken as inducements to infringe any particular patent. Dow Corning's sole warranty is that the product will meet the Dow Corning sales specifications in effect at the time of shipment. Your exclusive remedy for breach of such warranty is limited to refund of purchase price or replacement of any product shown to be other than as warranted.

DOW CORNING SPECIFICALLY DISCLAIMS ANY OTHER EXPRESS OR IMPLIED WARRANTY OF FITNESS FOR A PARTICULAR PURPOSE OR MERCHANTABILITY, UNLESS DOW CORNING PROVIDES YOU WITH A SPECIFIC, DULY SIGNED ENDORSEMENT OF FITNESS FOR USE. DOW CORNING DISCLAIMS LIABILITY FOR ANY INCIDENTAL OR CONSEQUENTIAL DAMAGES.

Dow Corning and Molykote are registered trademarks of Dow Corning Corporation.
©2003 Dow Corning Corporation. All rights reserved.

MOLYKOTE®
Smart Lubrication from Dow Corning